

# Opportunities for Fibre Optics on New Commercial Aircraft

Luke Bolton

Fibre Optics in Harsh Environments Conference  
7<sup>th</sup> May 2009



Document Ref: LS-DE-44709



imagination at work

**GE Proprietary Information** – The information contained in this document is GE proprietary information and is disclosed in confidence. It is the property of GE and shall not be used, disclosed to others or reproduced without the express written consent of GE, including, but without limitation, it is not to be used in the creation, manufacture, development, or derivation of any repairs, modifications, spare parts, designs, or configuration changes or to obtain FAA or any other government or regulatory approval to do so. If consent is given for reproduction in whole or in part, this notice and the notice set forth on each page of this document shall appear in any such reproduction in whole or in part. The information contained in this document may also be controlled by the U.S. export control laws. Unauthorized export or re-export is prohibited.

# Overview

# Overview

1. Fibre Optics on Commercial Aircraft: Current Status
2. Opportunities on New Platforms
3. Technology Drivers for Fibre Optics on New Platforms
4. Development Work at GE Aviation

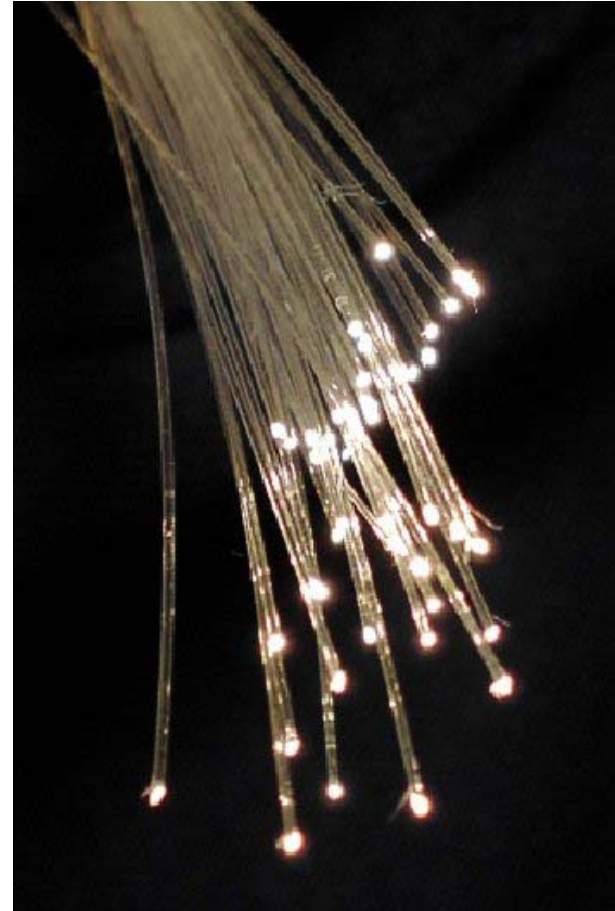

# Current Status



# Current Status – FO Technology

Deployment of FO has increased over time and the most recent platforms have provided the biggest steps in adoption of the technology

- Airbus A380 – Pilot Taxi-Aid Camera System, Flight Deck display links, Electronic Flight Bag, IFE + others?
- Boeing 787 – Common Computing Network, Flight Deck display links, Electronic Flight Bag, IFE + others (SATCOM) ?

Retrofit in commercial aircraft (with the possible exception of IFE) has not occurred

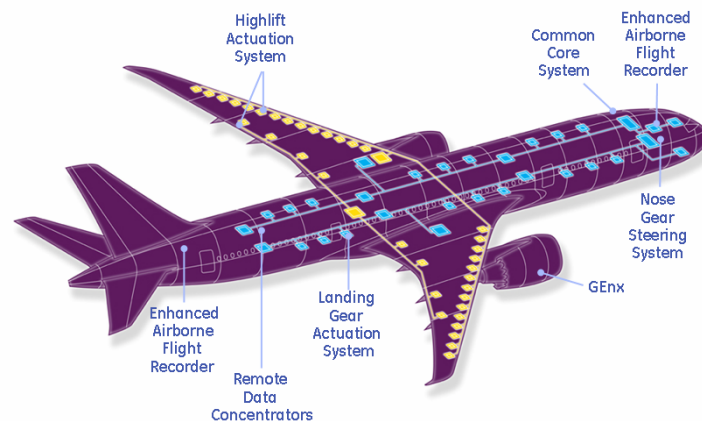

# Current Status - Airbus

Airbus A350XWB technology selected/frozen already.

Scheduled to enter service 2013 with Qatar Airways  
(Source: Flight International)

*“Citing economic uncertainty, Airbus will scale back production of its A320 family single-aisle aircraft from 36 to 34 a month beginning in October. Production rate of A330/A340 widebody aircraft will be held at the current level of 8.5 a month”* (Source: Avionics Magazine April 2009)

# Current Status - Boeing

New programs are being pushed back by delays on current platforms:

*“Boeing shifted the delivery date for the 747-8 Freighter to Cargolux from late 2009 to the third quarter of 2010”*  
(Source: Flight International)

787 Dreamliner expecting ~18 months delays – delivery target is now Q1 2010 (Source: Flight International)

# Current Status – Other Manufacturers

*“Gulfstream\* Aerospace Corp. will cut production rates for large and mid-size aircraft this year... will reduce large-cabin aircraft production from the projected rate of 94 to 73 and mid-size aircraft from 30 to 24.” (Source: Avionics Magazine April 2009)*

\* Gulfstream demonstrated fly-by-light in March 2008

*“Sales of business jets have slumped... Bombardier, maker of the Learjet and Challenger aircraft, today forecast a 25% fall in sales of its business jets and announced a 10% reduction in the workforce at its aerospace division” (Source: guardian.co.uk)*

# Opportunities on New Platforms

# New Platforms

Next generation of single-aisle Boeing 737 and Airbus A320 replacements are regarded as the big volume opportunities (~one aircraft per day<sup>1</sup> from each manufacturer).

The anticipated 737 replacement is now not expected until the *"latter half of next decade"* (Source: Flight International)

Anticipated A320 family replacement unlikely before 2015

This delay before they begin development means;

- there is time for some extensive technological innovation in order to ensure that FO is the physical layer of choice – the higher the readiness level, the lower the project risk
- the immediate opportunities for current technology may lie outside of the 'big two' (excluding IFE) e.g. bizjets, regional jets, emerging markets

1 T.K.Truong, "POF For Aircraft: Opportunities, Issues, Needed Technology," POF World West 2007, June 2007.

# IFE (In-Flight Entertainment)

IFE is unique in that it is a high-bandwidth system specified and selected by the airlines so the opportunity for upgrading existing systems are greater.

*“...the major IFE providers - particularly Thales and Panasonic Avionics – are designing systems that will require gigabit Ethernet (over 1000BaseT) connectors” (Source: Avionics Magazine Feb 2009)*

*“US Airways has launched its flight trial of Lumexis’s Fiber-To-The-Screen (FTTS) in-flight entertainment (IFE) system on an A320. The installation was designed and overseen by Inflight Canada, and FAA certification was accomplished through Aero Certification & Engineering.” Source: (www.lumexis.com)*

# Technology Drivers



GE Proprietary Information  
Subject to restrictions on the cover or first page

# High Bandwidth

High-bandwidth applications are the strongest niche for fibre optics and these applications will demand more bandwidth on new aircraft:

- Considerable increase in flight deck display link bandwidths driven by larger displays and video/synthetic vision requirements



- IFE backbone bandwidth increase with customers expecting greater functionality and choice on the system
- Avionics Data Network backbones migrating from 100Mbps to 1Gbps or even 10Gbps (although probably not on retrofit)

# Weight Reduction & EMC Performance

Two of the largest issues facing modern aircraft design are reducing weight (for fuel efficiency) and mitigating for the tougher EMC environment incurred by using predominantly composite materials in the aircraft structure

EMC immunity is an inherent benefit of optical fibre and can be capitalised on providing cost is addressed

Weight Reduction – need to make the most of the capabilities of FO to take out cabling weight and complexity – bi-directional comms, cost-effective Wavelength Multiplexing (WDM)

Cable Type	Approx Weight (kg/km)
Standard 2-conductor, #22, shielded	8
Databus shielded twisted pair, #24	18
Glass Optical Cable (Aircraft Spec)	4
Plastic Optical Cable (Automotive Spec)	4

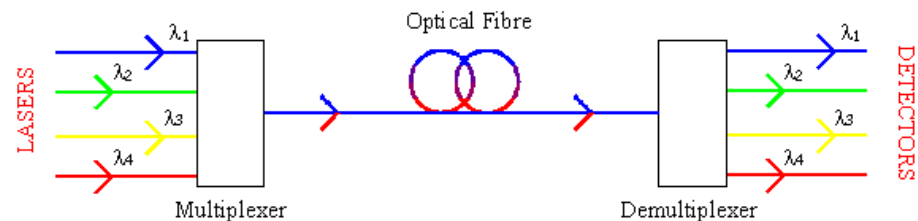

# Cost

To extend the scope of fibre deployment into lower-data rate regions of the avionics network and health management applications, where data latency and integrity are more important factors, cost must be addressed

At lower data rates, weight and EMC benefits are not sufficient to supplant copper physical layer – cost must be comparable

Also installation & maintenance infrastructure must be addressed – a lot of this is a perceived problem through lack of hands on experience but final assembly target for new aircraft is less than 5 days!

# Development Work at GE Aviation

# Next Generation Avionics Networks

Lots of interest in time-triggered (as opposed to event-driven) network architectures. Current protocol front-runners are FlexRay™, TTP™, TTEthernet™

Adoption of technology from automotive brings many benefits; low cost, wide supplier base (silicon & firmware), excellent tools support

High performance databus at prices closer to ARINC 429 than AFDX

# Topologies

Time-triggered nature gives determinism and tightly bounded latency – key attributes for aircraft networks

Data rate ~10Mbps sufficient for many applications

Going into service with several auto manufacturers including BMW and Audi

Can fibre optics provide a cost-effective physical layer? (Limited success in automotive industry)

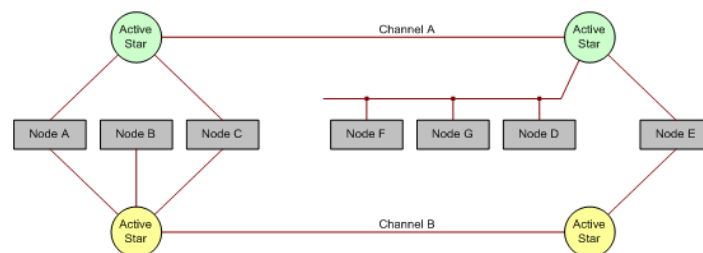
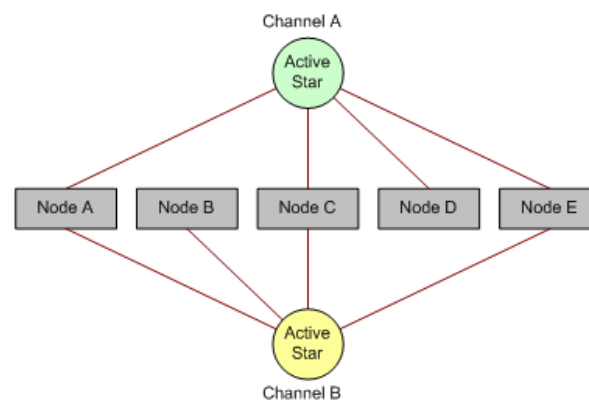
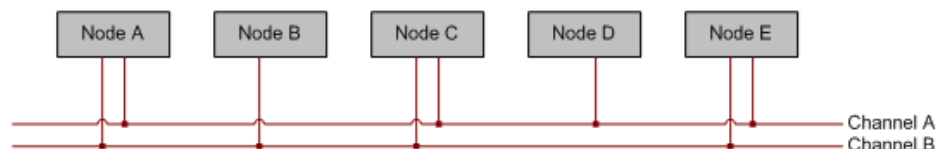

# FO Physical Layer for Time-Triggered Protocols

Glass Optical Fibre is technically capable but cost of complete cable/connector/transceiver solution is prohibitive when considered in comparison to incumbent technology

Consider a mid-size passenger aircraft ~250 passengers

High-speed network / GOF ~ 50 nodes

Low-speed network / electrical ~ 250 nodes

Cost of chipset for node is identical - difference is only at physical layer. Current factor GOF vs electrical for transceiver is ~x20

Running same fibre solution out to all nodes would increase cost of transceivers by 400%. Not including cable and connectors!

# New Physical Layer Technologies

Automotive have removed cost from system by looking to POF (Plastic Optical Fibre)

Large core, step-index fibres require lower precision alignment within connectors and active devices

POF alternatives: Polymer Clad Silica (PCS), Multi-core fibres (MC-GOF, MC-POF)

Technology is not directly portable into aerospace; packaging, temperature performance, other specific environmental requirements, physical range need addressing

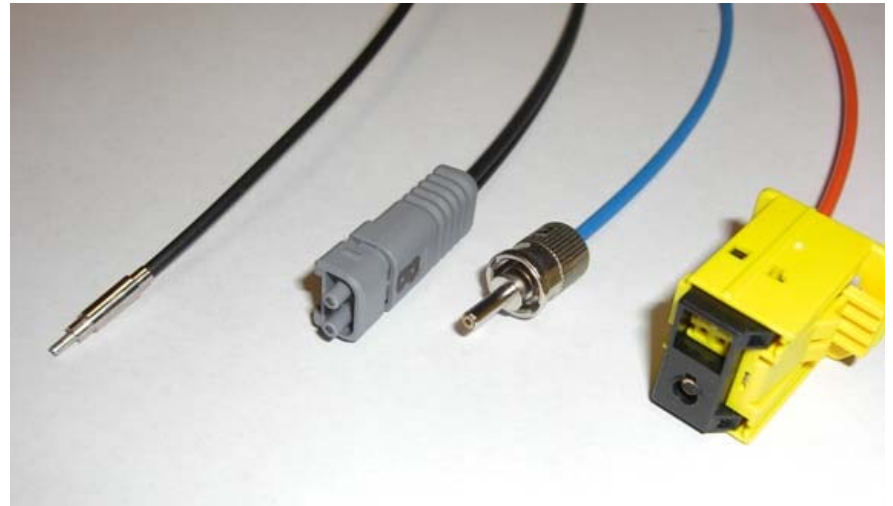

# Market size

Component manufacturers (particularly those from automotive) need to see a market to develop aircraft POF components

For new opportunities (production in 2015-2020)

- ~ 700 aircraft per year
- ~ 300 nodes per aircraft
- ~ 210000 nodes per year

Not including business jet, rotorcraft, military, test equipment

Redundancy at nodes would increase component numbers

# GE Aviation Demonstrator

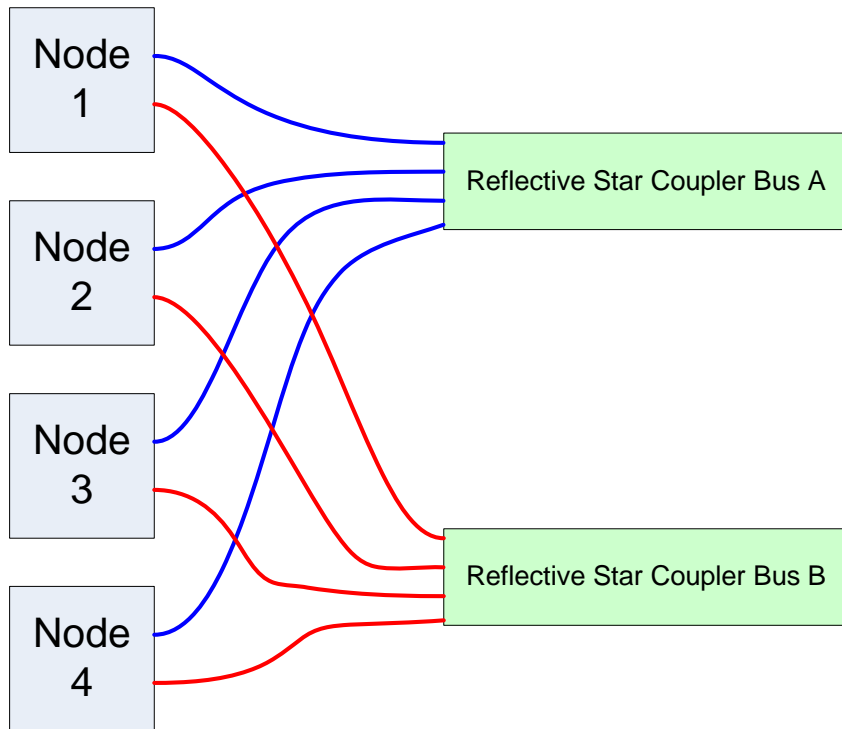

Passive star topology demonstrated over POF with time-triggered protocol.

Similar topology used in previous aircraft FO networks: Mil-Std-1773, STANAG 3910

Shared FO physical layer with minimum set of components



# GE Aviation Demonstrator

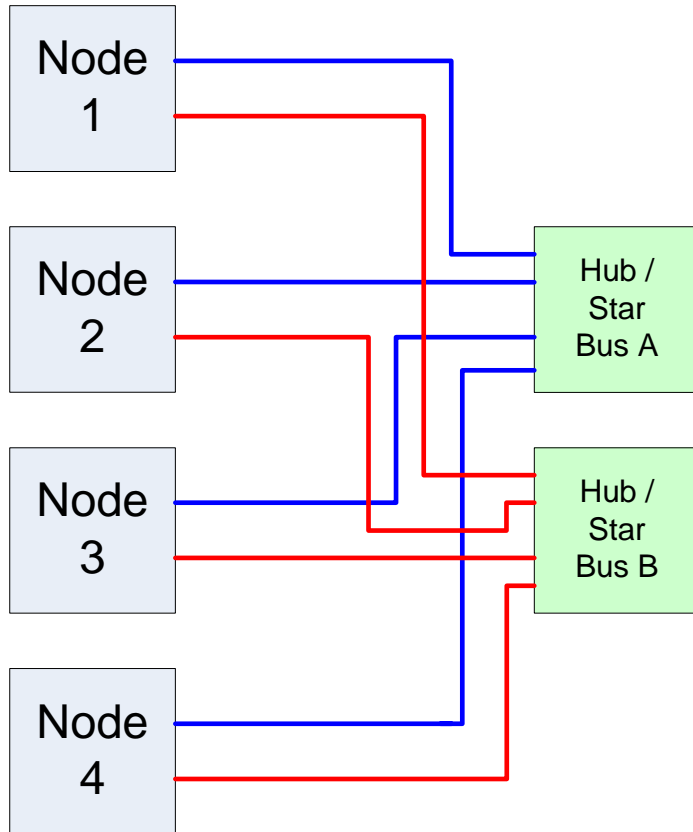

Passive star topology limited by transceiver power

Active star topology is a viable alternative - extends link lengths but increases cost of hub

Allows policing of 'babbling idiot' faults



# Other Technologies

Through the FONDA project, investigated WDM (Wavelength Division Multiplexing) and PONs (Passive Optical Networks) for weight reduction and reducing wiring complexity

Have not had appropriate opportunity to employ this technology yet but it does hold the key to greatly simplified physical layer topologies – single fibre per unit!

# Conclusions

Commercial aircraft business is under considerable pressure at the moment – pressure to deliver on current programmes and pressure from economic environment

The delay in developing new platforms is a good opportunity to develop cost-effective fibre solutions to a high readiness level

Can build on niche applications but largest volume opportunities come from migrating into new areas

Focussed on avionics here but sensors, health management, power-by-light, RF-over-fibre, cabin lighting are all being considered

# Acknowledgements

Technology demonstrator work has been partially funded by the UK TSB (Technology Strategy Board)

# Thankyou for listening!

## Questions?