

## De-risking future avionic optical physical layer using OSCAR



Geoff Proudley  
Photonics Group  
Advanced Technology Centre

## Outline of Talk

- What is OSCAR?
- What is its role?
- Example of prototype harness on OSCAR
- Some Results
- Conclusions

A typical platform fibre optic harness (during build)

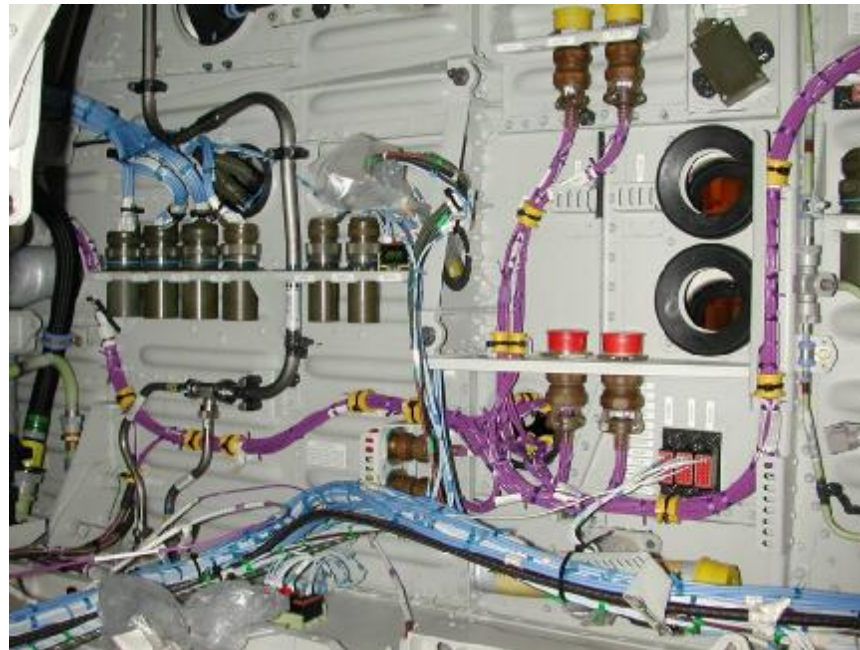

**Wouldn't it be good if we could simulate future optical physical layers in the lab with prototype components, representative cable lengths, routing, connector breaks and even harness abuse?** ü

**And allow environmental testing?** ü

**.....This led to the concept of OSCAR**

## What is OSCAR?

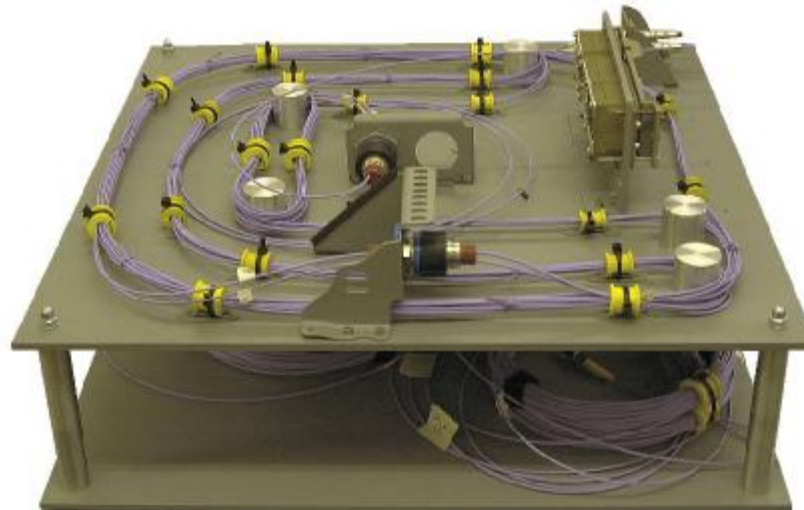

### Optical System and Component Assessment Rig

- = Network harness simulation for platform installation (cable, connectors, transceivers... in a small space envelope.
- = A tool for confidence testing proposed future sub-systems.

## Future components can be tested individually



Transceivers

How will they work as a complete system with installation constraints, connector losses, modal effects, environmental conditions etc?



Connectors



Fibre Optic Contacts

= Role of OSCAR



Prototype Cables



Novel Components

## OSCAR

Concept = Interconnected panels to form a network. Small space envelope allows testing in environmental test chamber

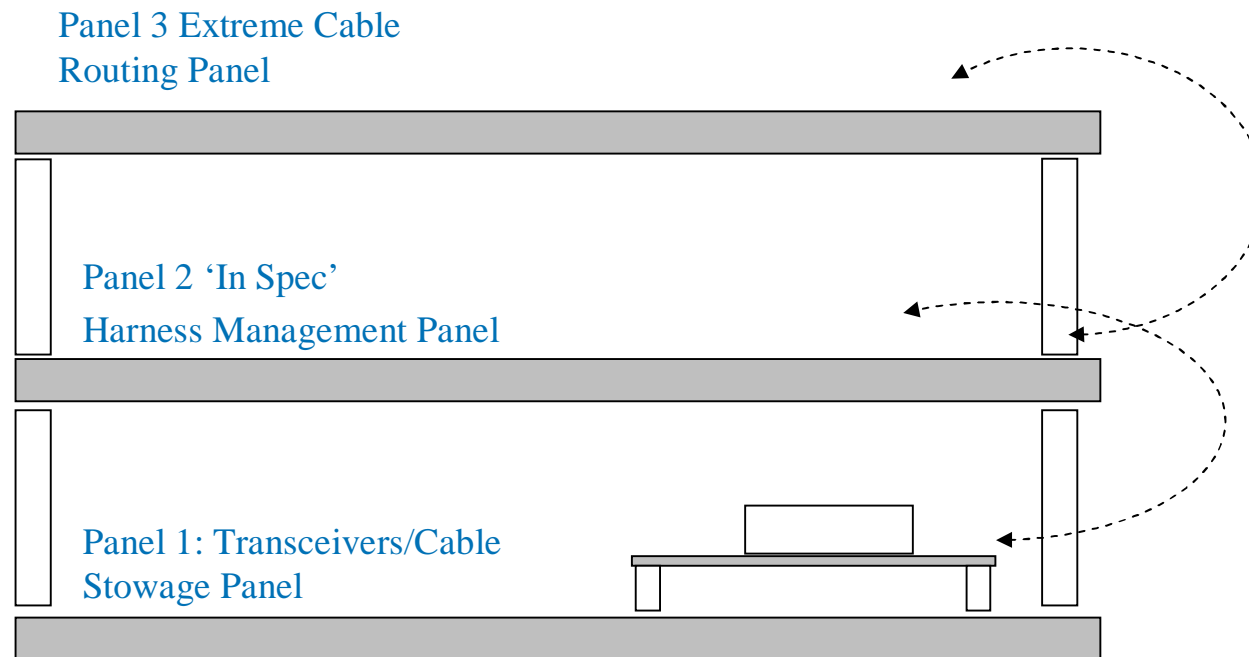

**OSCAR Panel 1 (Spool Panel) – 25m and 50m spool lengths (duplicated)**

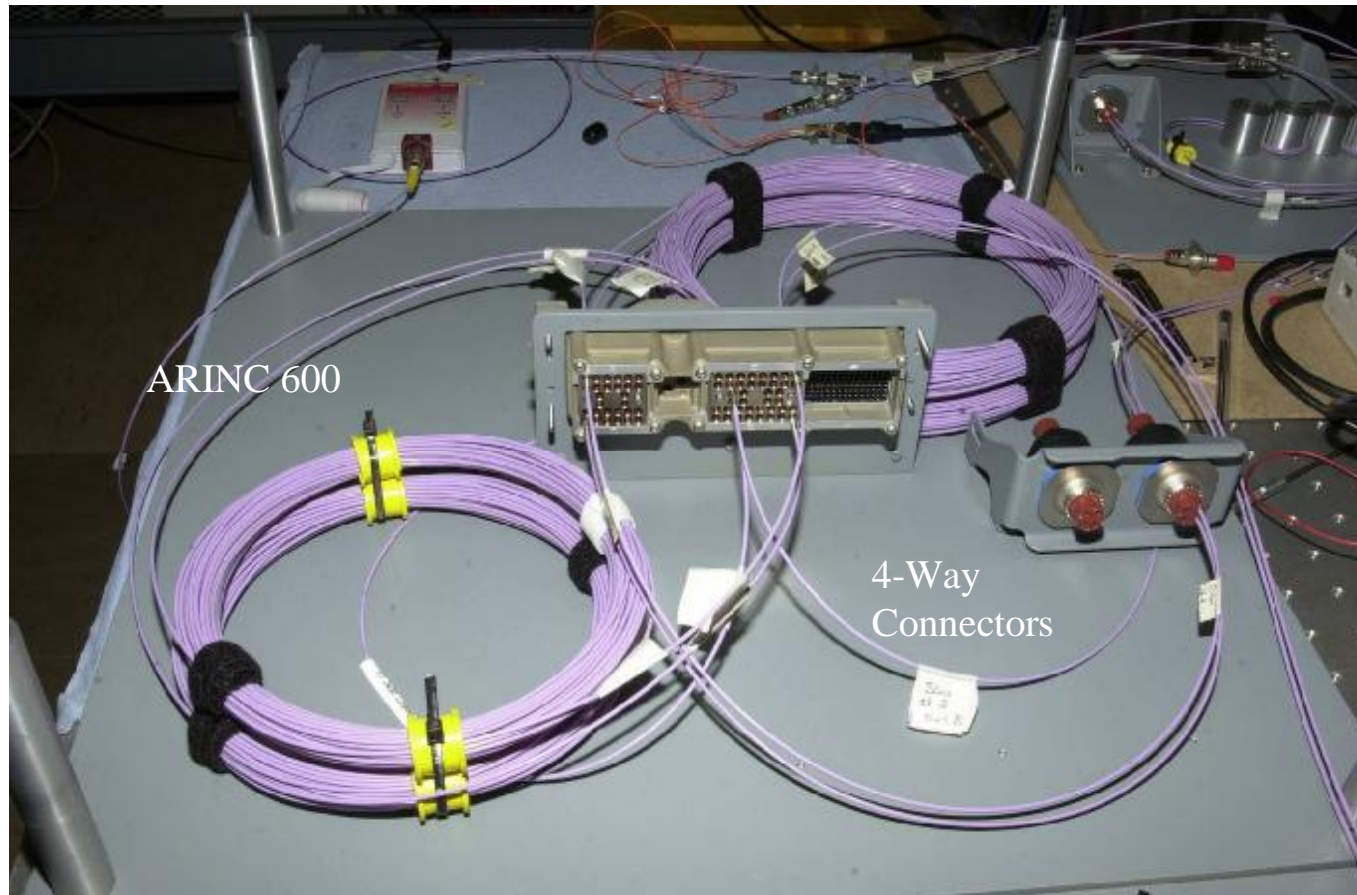

## OSCAR Panel 2 (In Spec Panel) - ~5m and 15m lengths (duplicated) Representative cable management as per platform

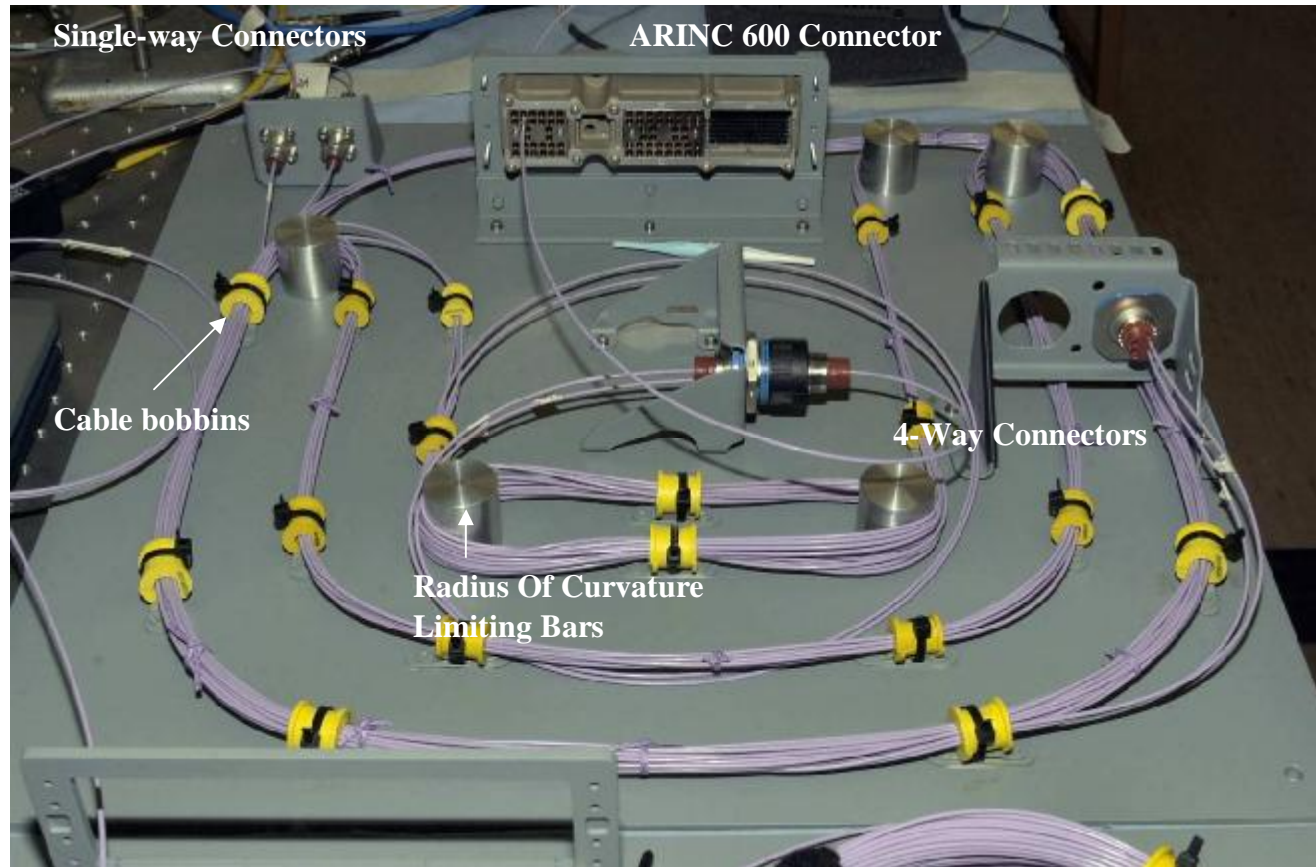

## OSCAR Panel 3 (Dirty Panel or 'Naughty Board') – Extreme routing examples ~5m

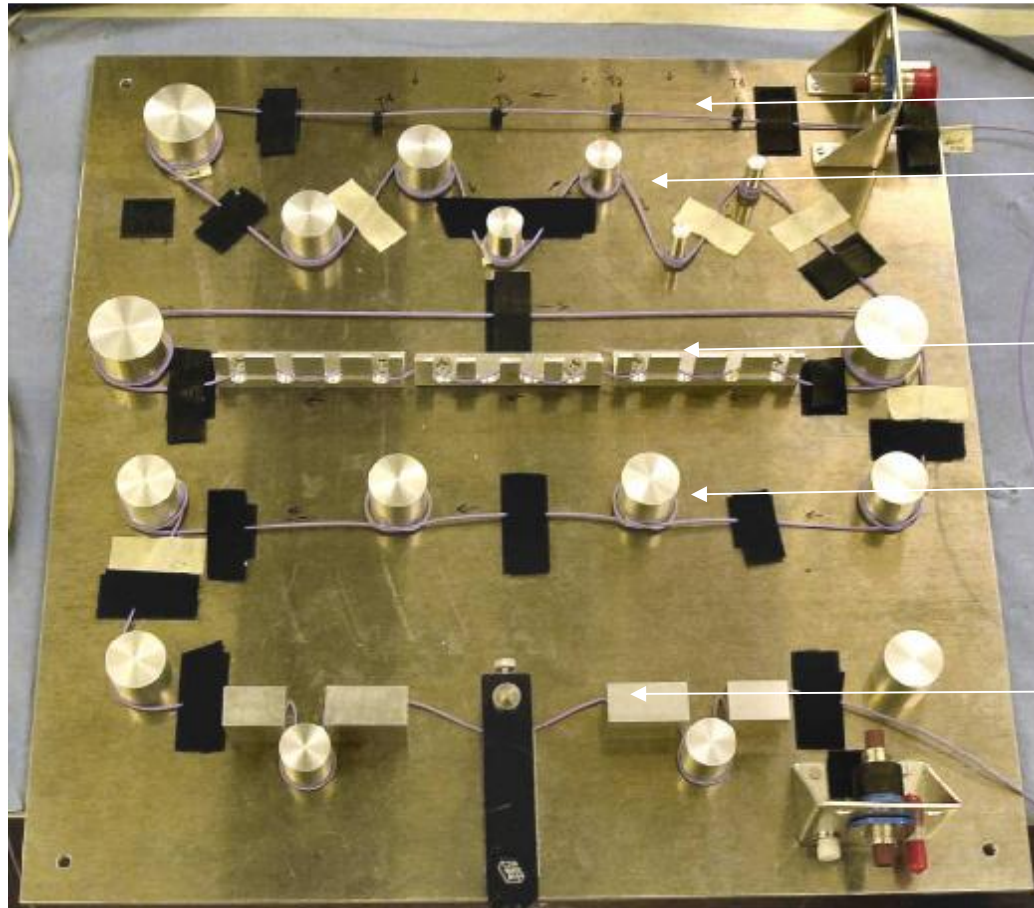

**Cable Ties**

**Decreasing  
ROC wraps**

**Slot Weave**

**Knotted Twists**

**Hard Edge  
Loading**

**Connector  
Interface**

## OSCAR Panel 3 Various Features



**ROC Wraps**

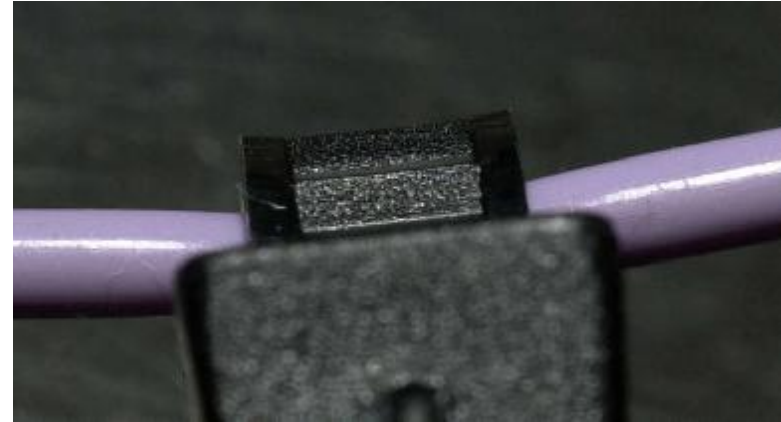

**Cable Tie**

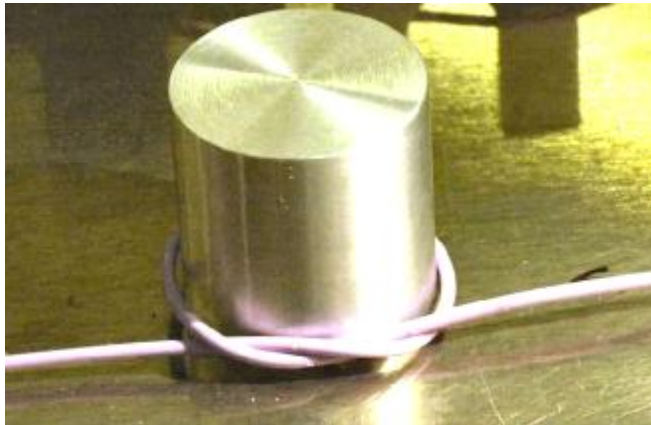

**Knot Twists**

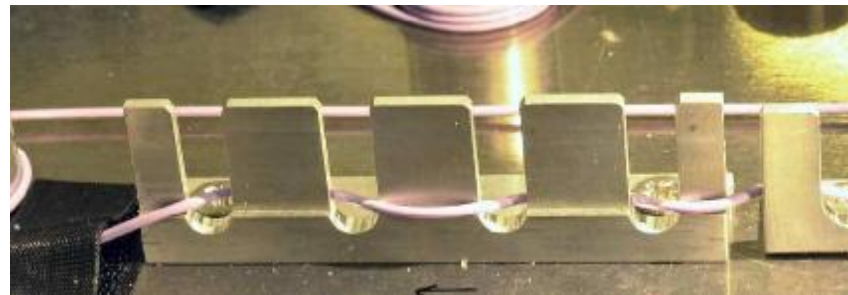

**Slot Weave**

## OSCAR Panel 3 Hard Edge Loading Feature

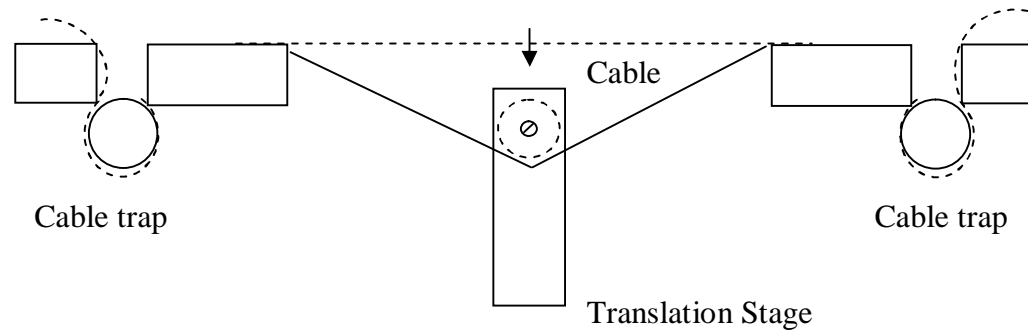

## OSCAR Panel 3 Hard Edge Loading Feature

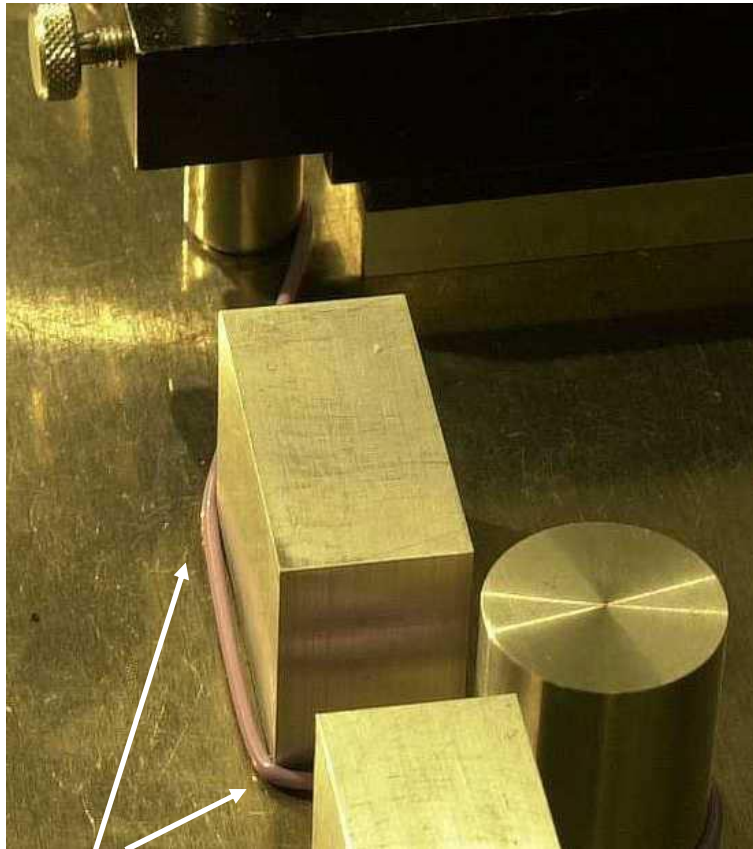

**Hard Edge Loading**

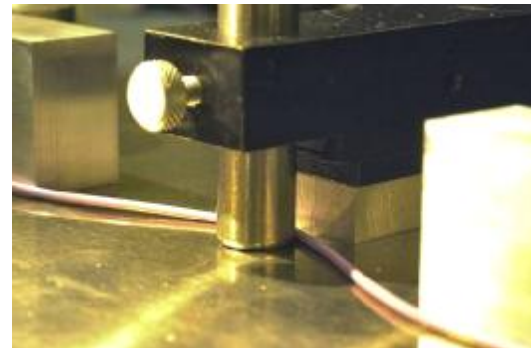

**Tension Micrometer**

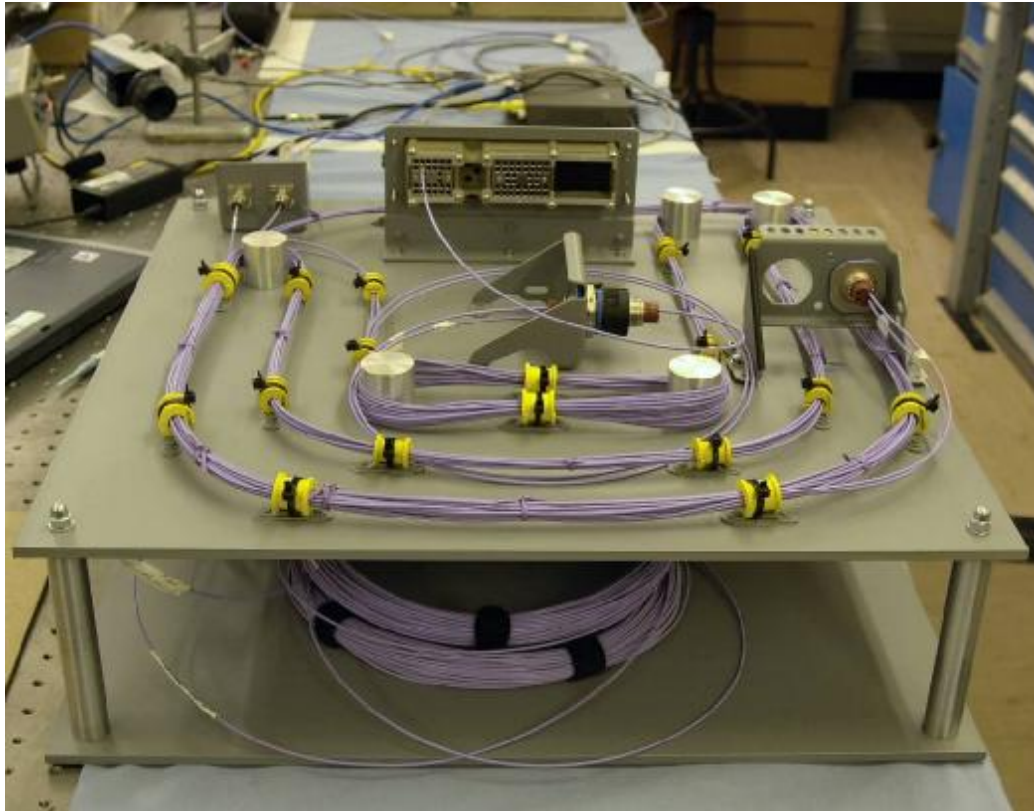

**OSCAR Panels 1 and 2  
Stacked**

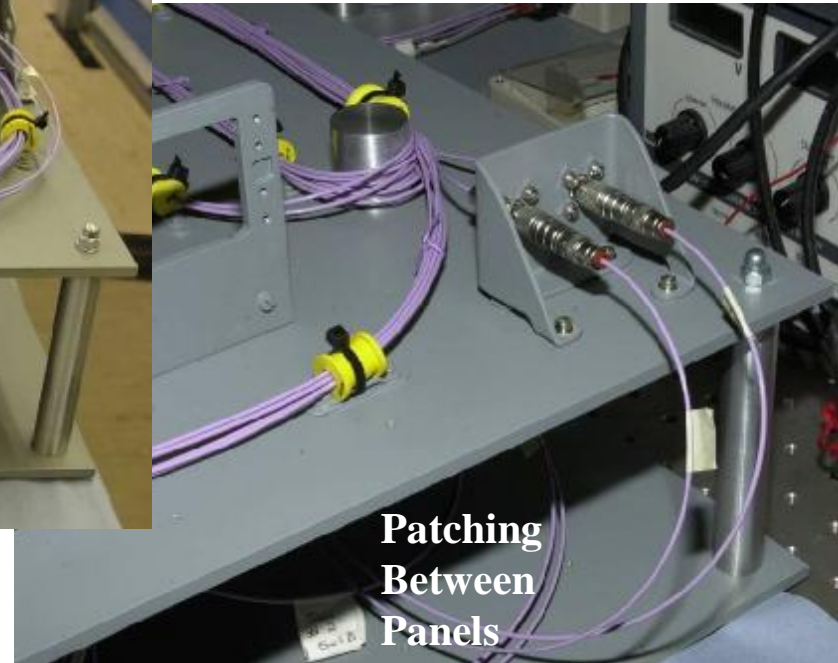

**Patching  
Between  
Panels**

## OSCAR – Patching between panels



The panels can be patched in any order

## OSCAR – Path Options

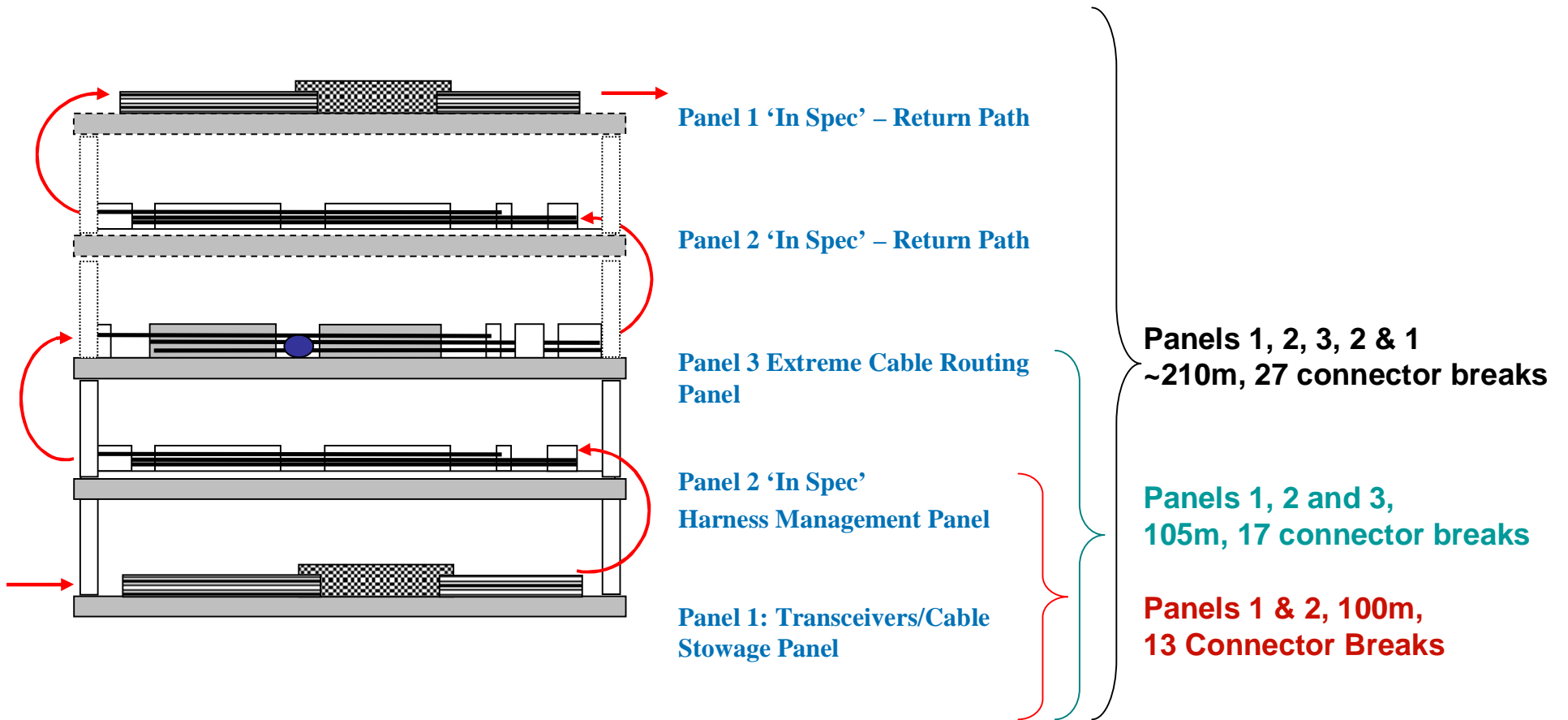

## OSCAR – Example of Path Testing (3 Panels)

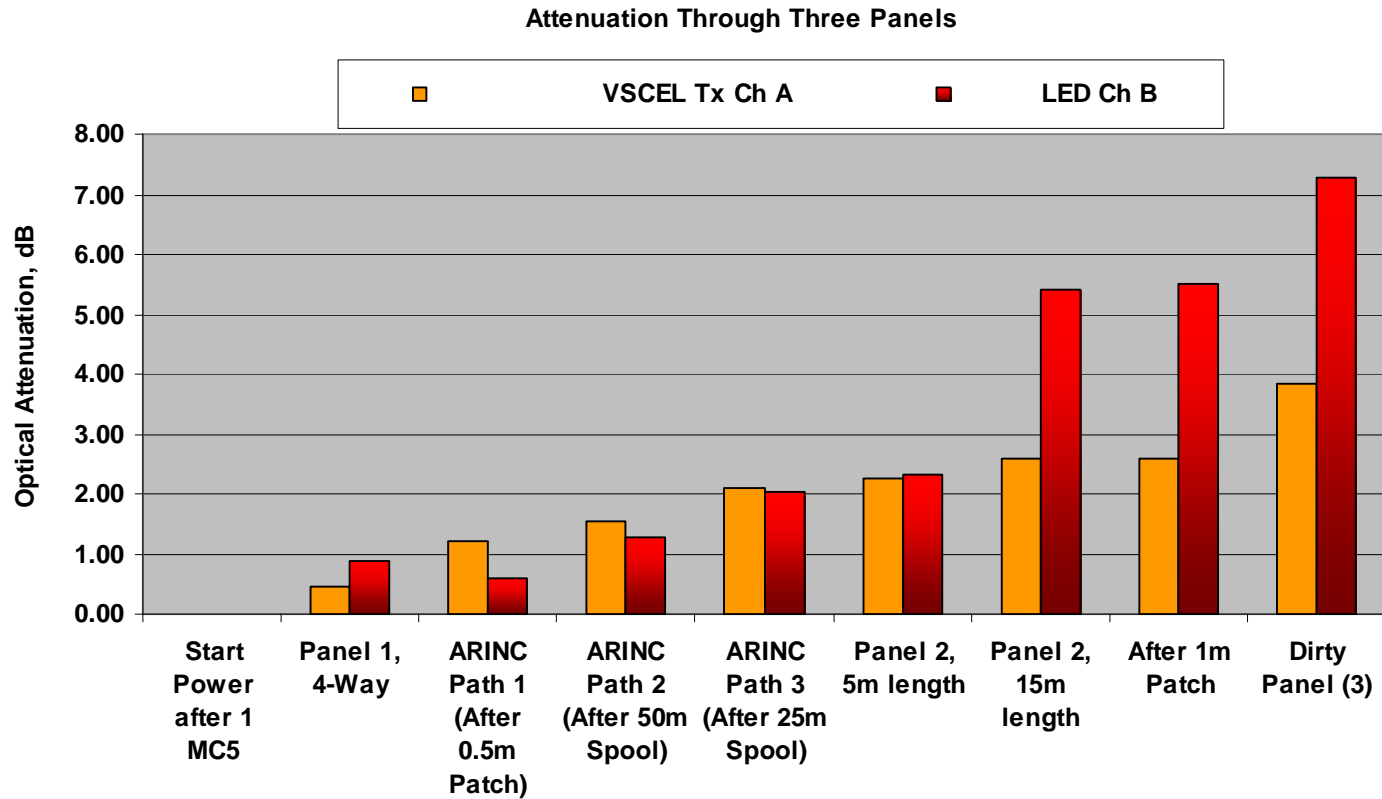

## OSCAR – Ready for Environmental Testing



## Prototype Harness Test -55 to 125C x 5 cycles - VCSEL power split to allow multi-path testing

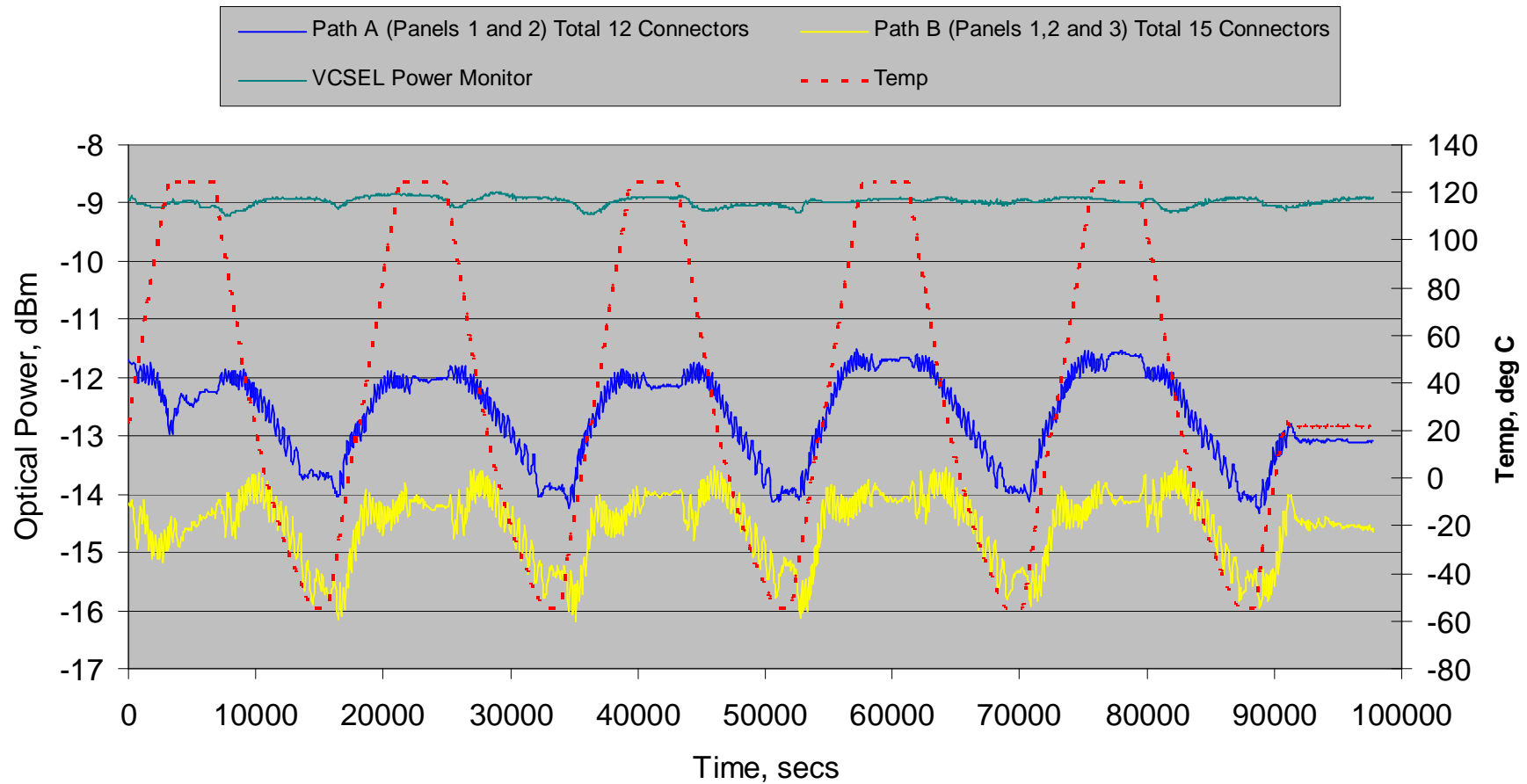

## Data fidelity through network (Worst case - low temperature)

Eye Diagram at 1.2442Gbps  
PRBS data

850nm VCSEL transceiver

Good Fidelity

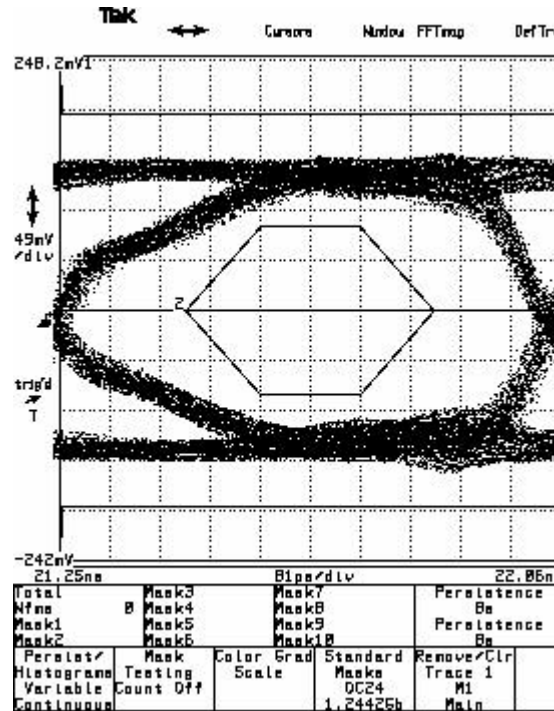

Long Path (~210m + 27 Connector Breaks and extreme cable routing) – 5 Panel Route

Harness at  $-55^{\circ}\text{C}$ , Power to Rx = -11.585dB

Tx VCSEL launch (power = -2.602dBm)

Attenuation at  $-55^{\circ}\text{C}$  = 8.983dB

Direct & Split (via coupler) VCSEL Tx Attenuation Through Rig Paths at 1.2442Gbps

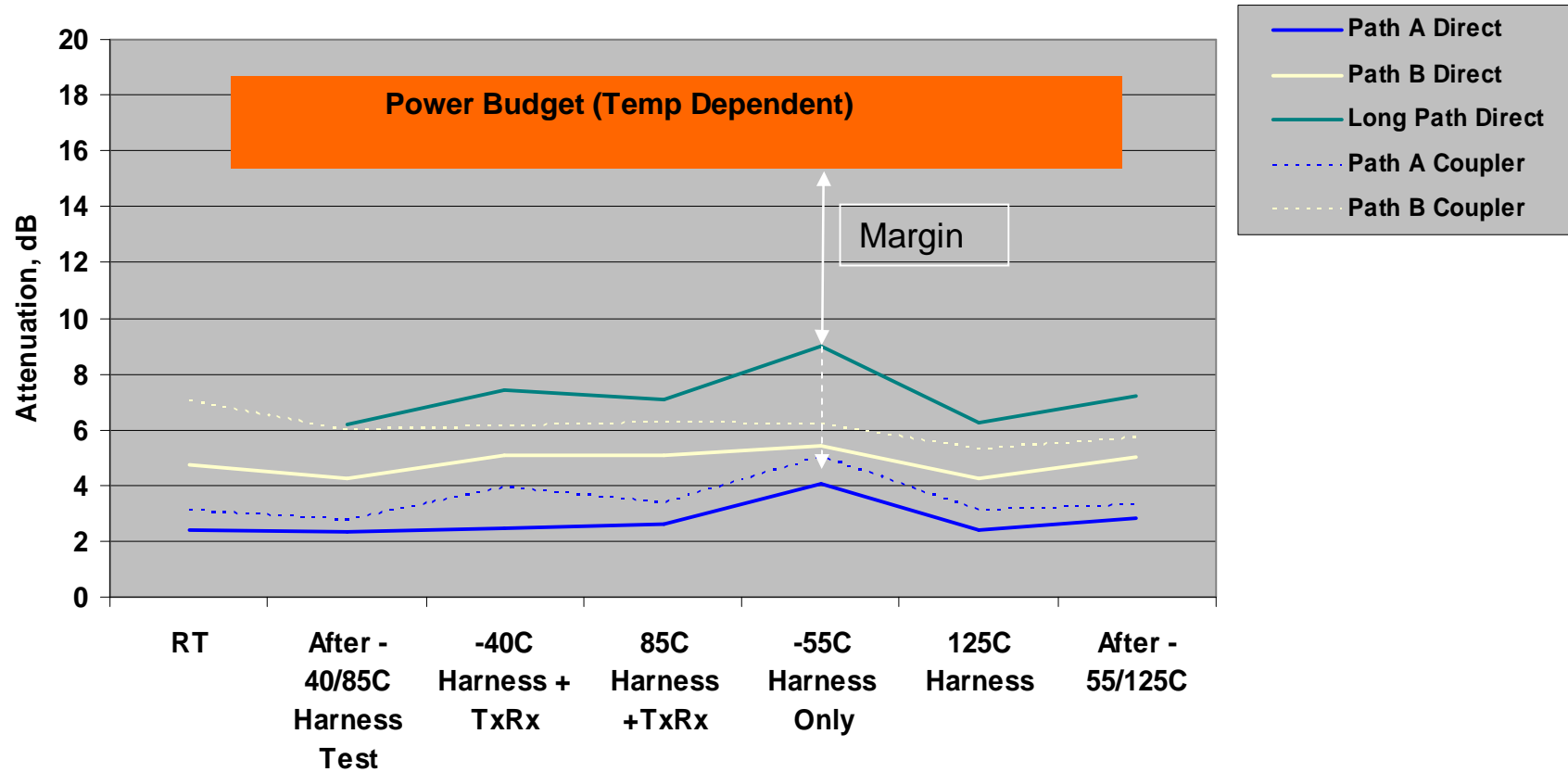

Approximate Power Margin at 1.2442Gbps, Direct VCSEL transceiver launch into harness

**OSCAR** – Approximate Power Budgets at 1.2442Gbps, Direct 850nm VCSEL transceiver launch

<b>Path</b>	<b>Insertion Loss (Worst Case over Temp)</b>	<b>Worst Case Power Budget Source to Receiver</b>	<b>Remaining Power Margin</b>
<b>A (Panels 1 and 2, 100m, 13 Connector Breaks)</b>	<b>4.1dB</b>	<b>15.5dB</b>	<b>11.4dB</b>
<b>B (Panels 1,2 and 3, 105m, 17 connector breaks)</b>	<b>5.4dB</b>	<b>15.5dB</b>	<b>10.1dB</b>
<b>C = 5 Panels, 210m (1,2,3,2 and 1 route), 27 connector breaks</b>	<b>9.0dB</b>	<b>15.5dB</b>	<b>6.5dB</b>

## Head-to-Head Cable Comparisons (Common Routing)



-60C

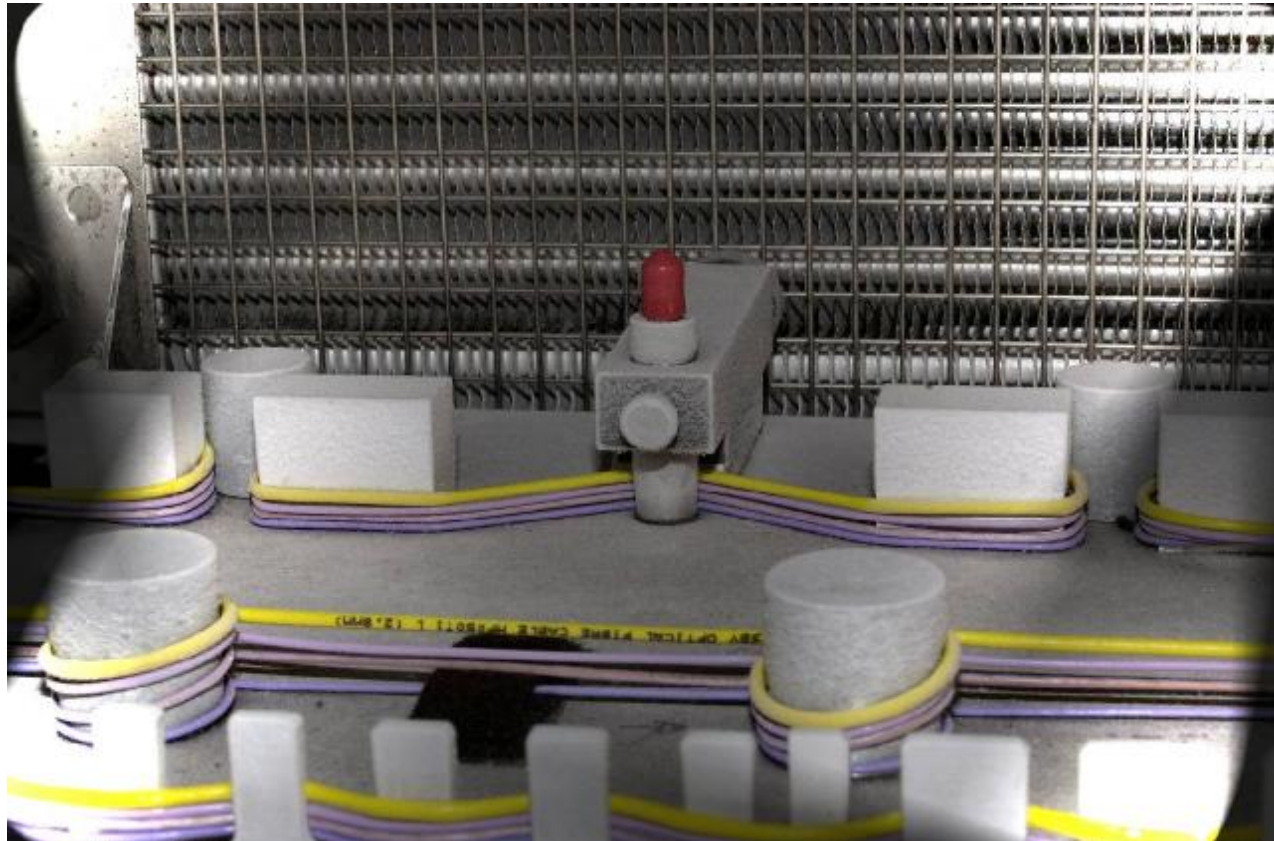

## Head to head cable comparison on OSCAR (different NA variants)

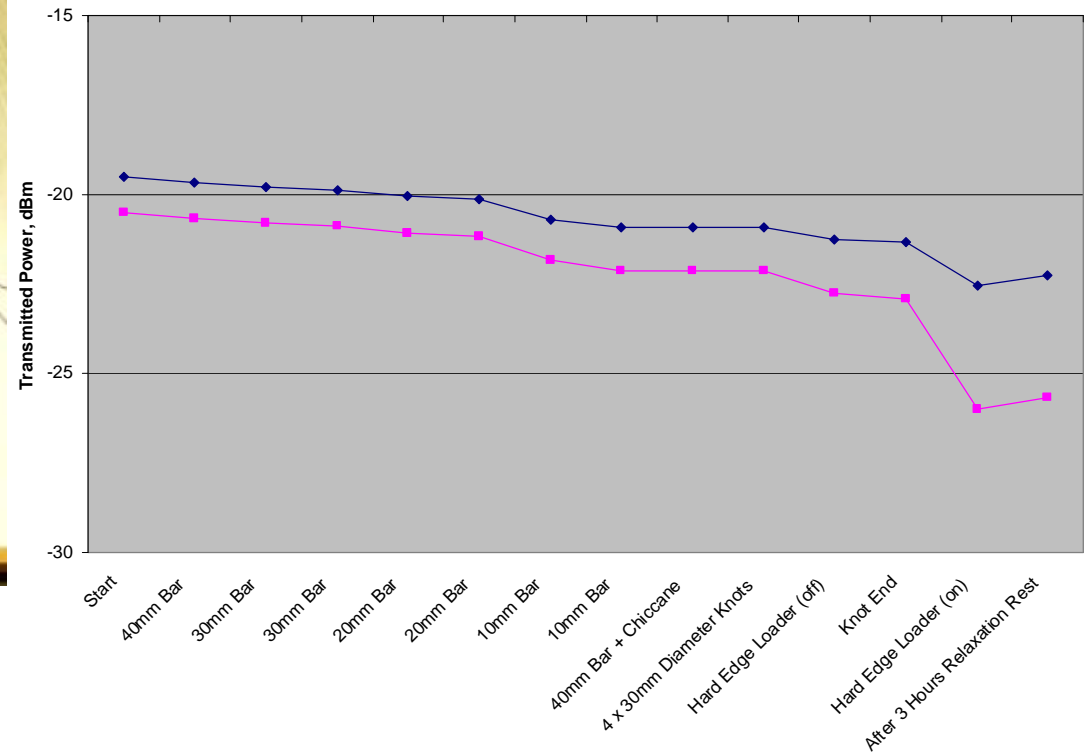
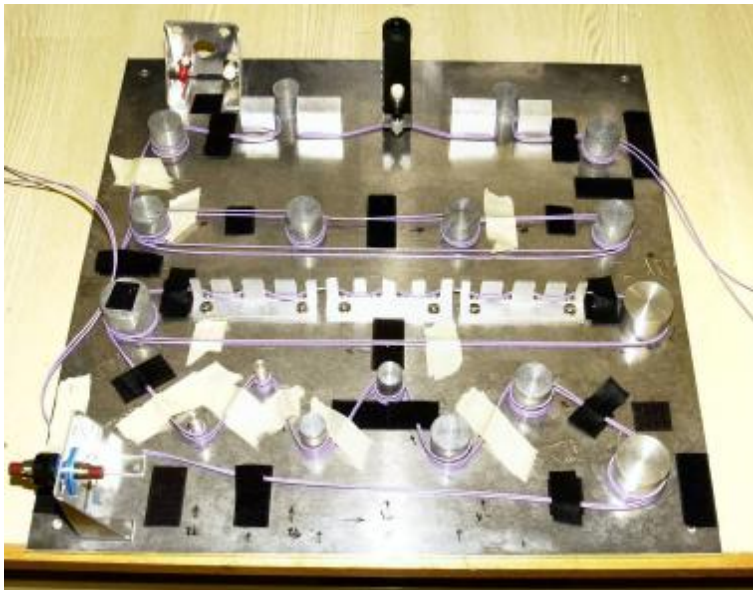

## OSCAR - Conclusions

- A useful tool in confidence testing prototype future network harnessing
- Sub-systems can be 'built' by patching panels in different orders
- Extreme cable routing tests with 'Naughty Board' (Can be patched at different points in the network path)
- Environmental testing possible with power or data monitoring through network
- Head-to-Head comparisons of different prototype components (e.g. cables)
- Can be used to compare different light source launch conditions through harness
- New panels can be mounted and cables re-wound e.g. testing single-mode, multi-mode, POF networks...

## OSCAR - Conclusions

Short of installing the network on a platform, OSCAR gives confidence that components will work together in a representative environment.

This can go a long way to showing maturity (e.g. Technology Readiness Levels) with system prototype demonstration in an operational environment.