



Field termination and repair for harsh environment fibre optic cable

Diamond: today's solutions to meet
tomorrow's needs

F  **HEC'11**



A UNIQUE PROCESS – Active Core Alignment (ACA)

→ Multi-component Diamond ferrule with metal insert

(Active Core Alignment)

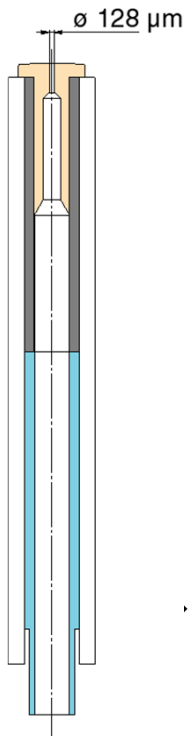

- ▶ Reduced fiber core eccentricity (0.25µm max), results in consistently low Insertion Loss values
- ▶ Geometric parameters under control (Apex, fiber high, radius)
- ▶ Full compatibility with other technologies (monoblock ferrule)
- ▶ Excellent Return Loss values thanks to an high quality polishing process

MONOBLOCK FERRULE (other technologies)

(Tuning)

- ▶ Geometric parameters dependent from production process

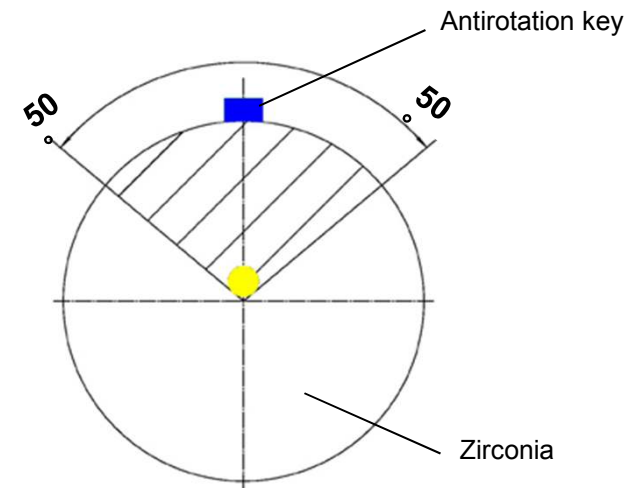
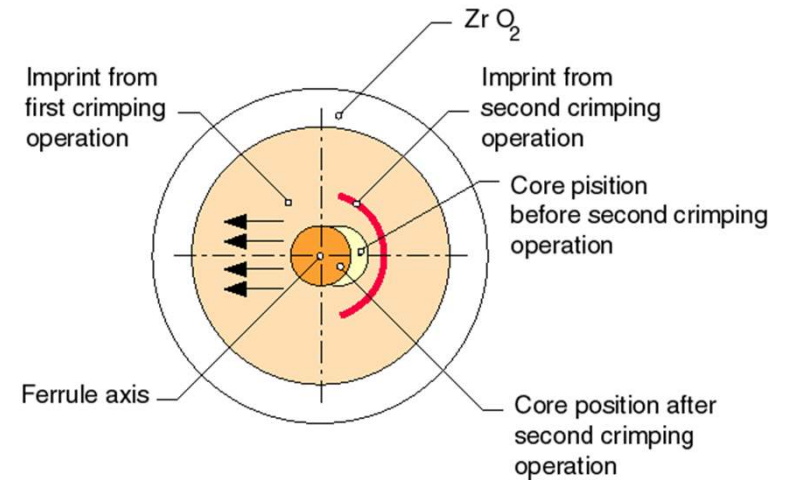



Cable Repair

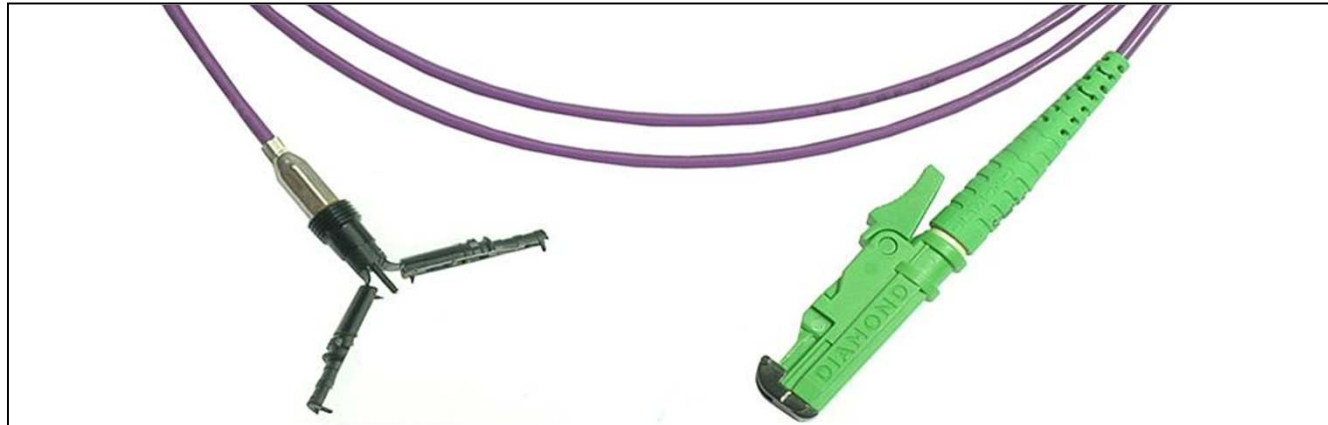

- The Repair set permits secure repairs, of already installed cables, avoiding their replacement. This remarkably reduces maintenance expenses and wasted time while re-establishing interrupted fiber optic links.



Challenging: Crocodile repair set / splice unit

→ Current situation:

- F/o cable (multimode, ABS0963-003LF) is currently deployed in several systems across Airbus fleet.
- If a f/o harness is damaged, all subjected VB's have to be replaced.

→ Impact:

- The current procedure of replacing complete links is very time consuming. Spares have to be ordered and they have to be installed on a/c.



Damage scenario

- Two possible ways of f/o harness damages have been identified which impair the reliability of operation:
1. Damaged optical contacts within a connector
 2. Broken optical fibre within a link.

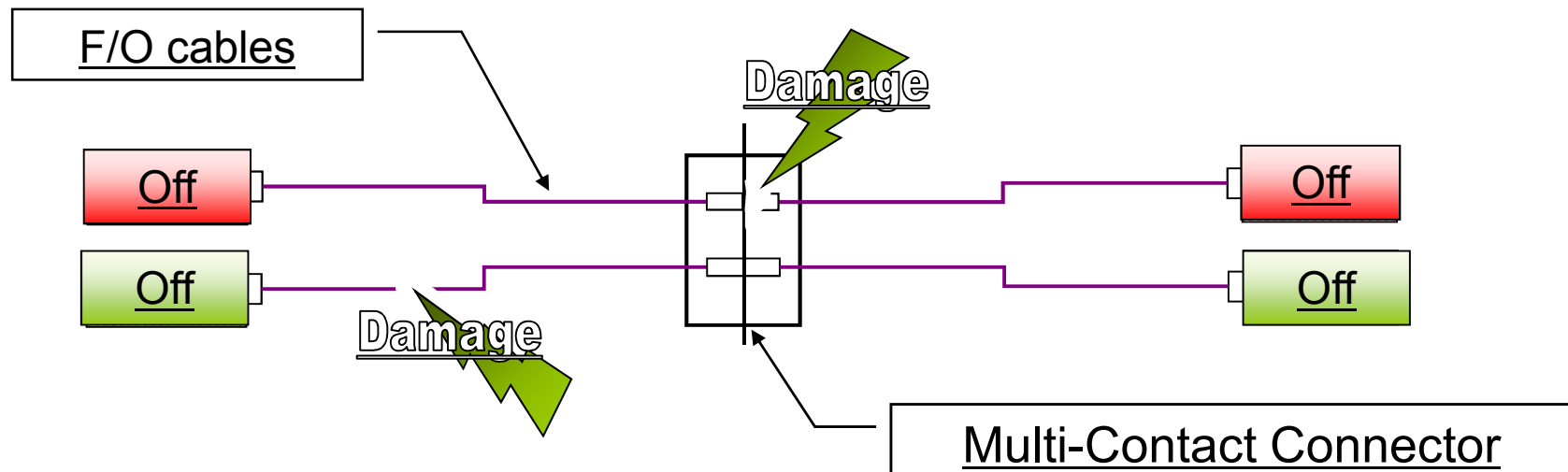



Repair steps

The damages can be fixed by replacing them with pre-manufactured pigtails or cable sections. They just need to be cut away...

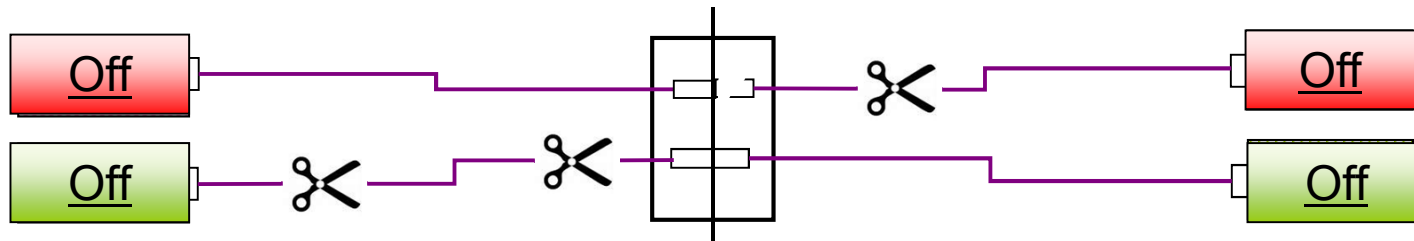

... and new sections have to be spliced in:

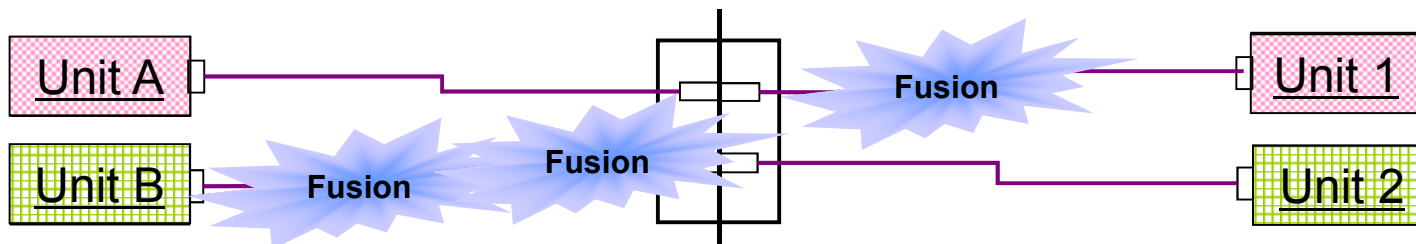

The systems can be turned on into operative state again



Construction of repair set

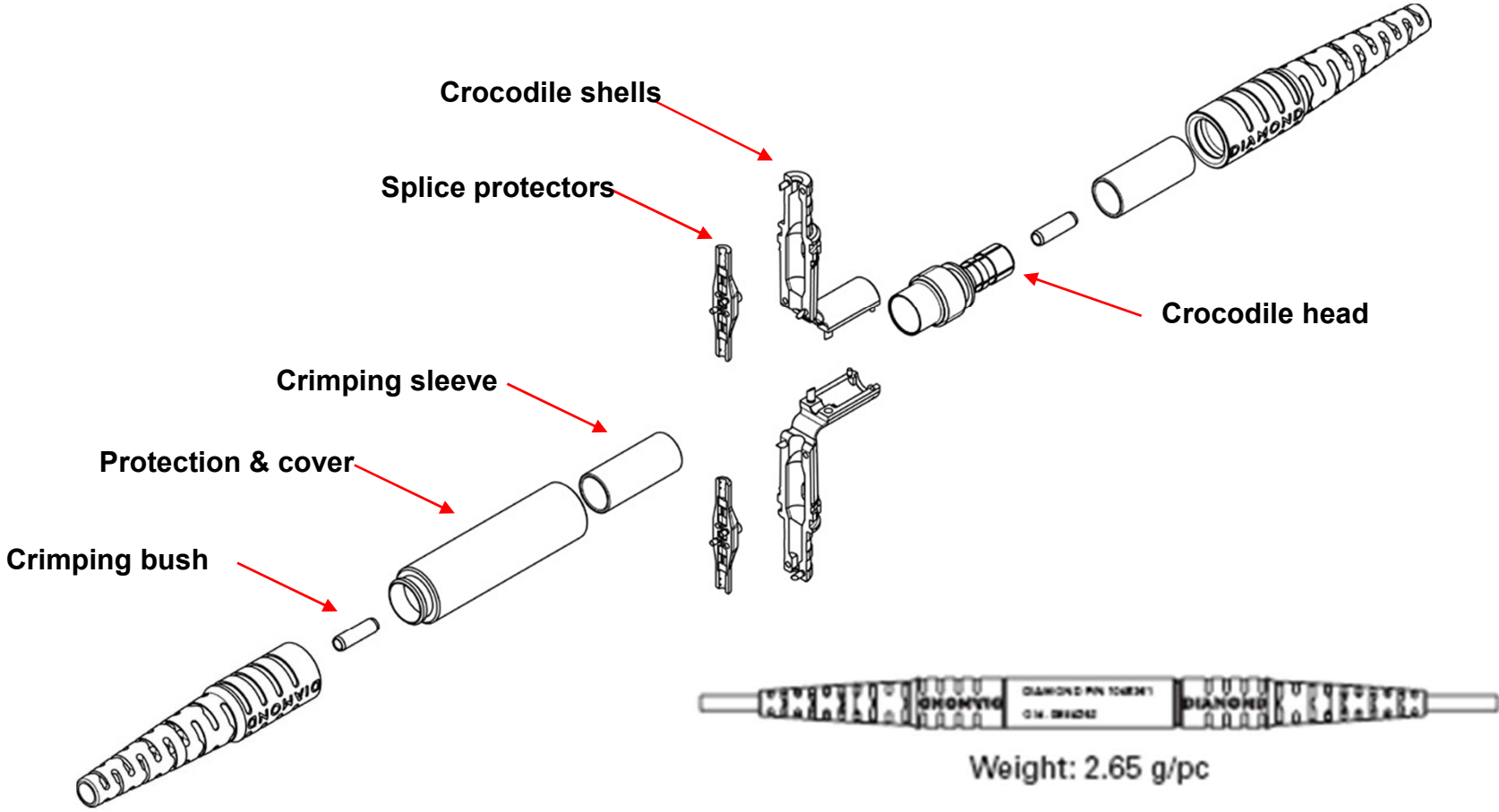



Repair toolkit:



Ruggedized toolcase



•Clear overview of the tool case permits quick check for completeness, after finishing the job.

•Bright colours of the tooling permits easy recognition and use in dark operational areas.



Repair toolkit:

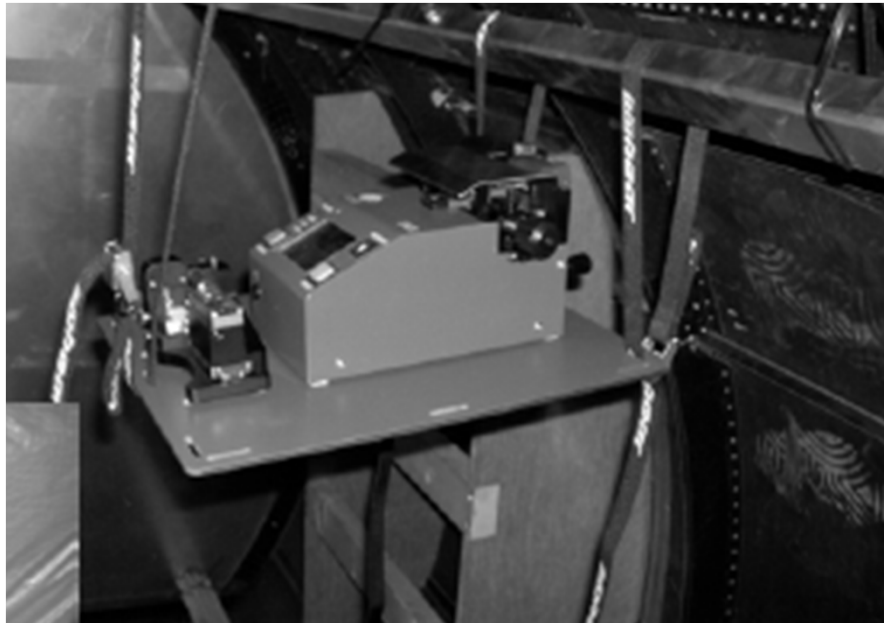

The toolkit includes also a head lamp, a platform with adjustable fixing belts to allow secure operation even in difficult conditions within airframes and uncomfortable positions.



Splicing steps (procedure)

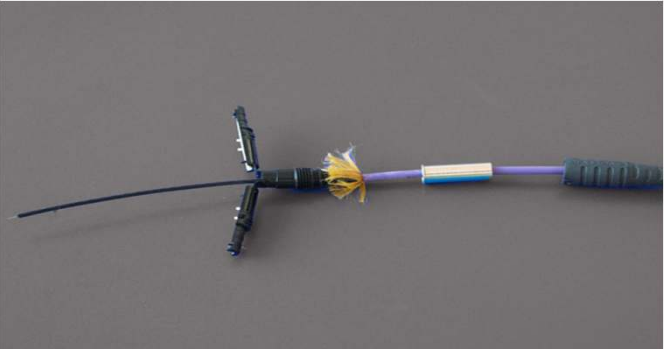

Put and fix the special crocodile onto the prepared cable

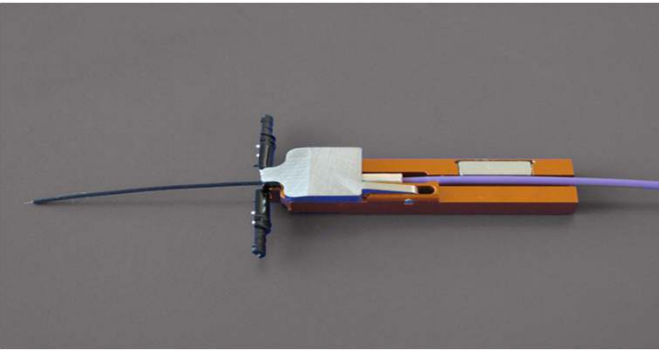

Place the mounted crocodile into the crocodile holder

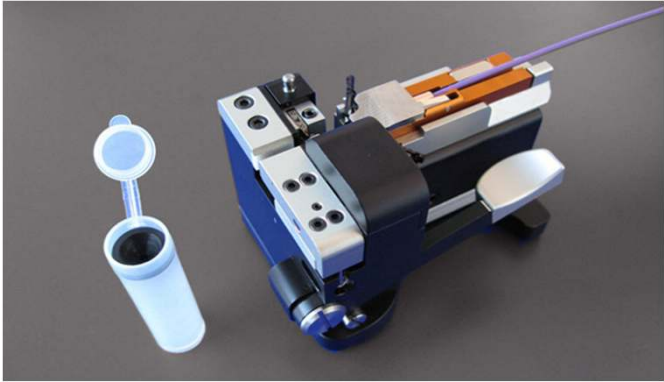

Cut the fiber at the right splice length

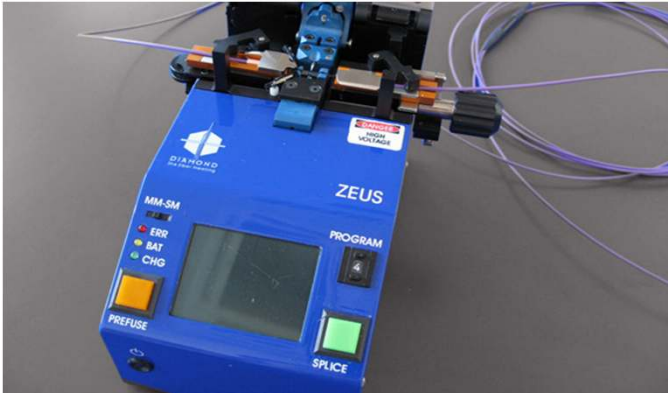

Prepare the other cable end. Splice the fibers together.



Splicing steps (procedure)

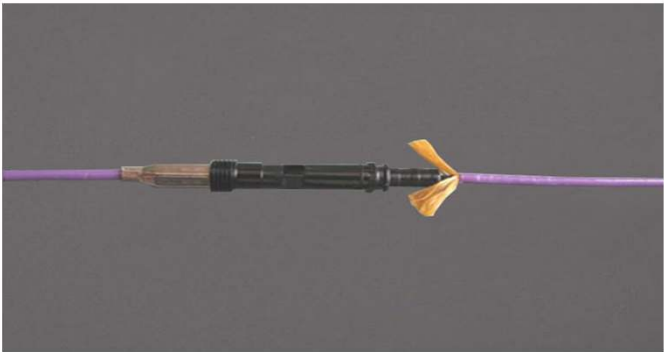

Close the crocodile and crimp the sleeve on it



Screw the protection onto the crocodile head and slide cable boots



Cable 100% joined



Specifications of the cable repair:

Optical performances

Fibre type	GI 62.5/125µm	Unit
Insertion Loss (IL)	Typ. 0.1 ≤ 0.15 (95%)	dB*
Cable pulling	100	N
Temperature range	-60 / +150	C °
Gemessen bei 100% Beleuchtung		



Specifications of the cable repair:

Mechanical & environmental performances of the cable repair

Rapid temperature change	-60/+150° C	EN 2591-6305 λ=1310 nm
Temperature endurance	1000h@150° C	EN 2591-301 λ=1310 nm
Thermal cycling	-60/+150° C, 15 cycles	IEC 61300-2-22 λ=1310 nm
Cold lowe pressure damp heat	-60 ° C; 10 cycles	EN 2591-303 λ=1310 nm
Salt mist	500h	EN 2591-307 λ=1310 nm
Sand & Dust	8.9 m/s; 1cycle	EN 2591-309 λ=1310 nm
Damp heat cycling	10cycles	EN 2591-6321 λ=1310 nm
Flammability	Method A	EN 2591-317 λ=1310 nm
Fluid resistance	Fluid 1,3,9,10,11.15 per EN 3909 Method 1	EN 2591-315 λ=1310 nm
Mould growth	Method A; 28 days	EN2591-306 λ=1310 nm
Cabling cycling flexing	Method C; 100 cycles@40 N	EN2591-609 λ=1310 nm
Cable pulling	Method B; 100N; 1 min; 3pulls	EN2591-610 λ=1310 nm
Cable torsion	100 cycles@40 N	EN2591-611 λ=1310 nm
Radial compression	500N; 15 sec. 2 axis	EN2591-614 λ=1310 nm
Random vibration	Method B; Figure 2; Level J; 8h/axis	EN2591-403 λ=1310 nm
Shock	Method A; sev. 50 shock/dir. On 2 main axis	EN2591-402 λ=1310 nm



Features and benefits

- Simple, fast and reliable repair
 - Reduces operator error and time

- System based on standard splicing process
 - Today`s most precise and reliable solution for permanent fiber connection

- Integrated, small and robust splice protection and cable boots
 - Avoids cost and reduces the space requirements associated with additional splice trays and boxes

- Compact, lightweight